DB-889D Multiplexer Board	2
1. Function Description.....	2
1.1 Features	2
1.2 Applications	2
1.3 Specification.....	2
2. Installing	4
2.1 Layout	4
2.2 Jumper setup.....	5
2.2.1 JP0 ~ JP15 Analog Input R/C Filter.....	5
2.2.2 JP16 Analog Output Channel Jumper	5
2.2.3 JP19 Internal / External Power selection	6
2.2.4 JP18 Local / Remote Gain control	6
2.3 Pin Assignment	8
3 Analog input & Gain setting	9
3.1 Input Channel Selection	9
3.2 Gain Setting.....	10
3.3. The Thermocouple Input	11
3.3.1 Voltage - TO - Temperature Conversion	12
3.4 CJC Output.....	13
4 Signal Connection.....	14
4.1 Floating Signal Connection	14
4.2 Non-Floating Signal Source	15
4.3 Cascading DB-889D.....	16
4.4 Open Thermocouple Detection.....	17
4.5Block Diagram	18
5 Programming	19
5.1 Using A-822PGL.....	19
5.2 Example Program.....	20
6. Calibration	22
6.1 Calibration VR Description	22
6.2 Calibration Steps	22

DB-889D Multiplexer Board

1. Function Description

The DB-889D is an expansion multiplexer / amplifier board for use with A-82X, PCI-1800 series. Each 889D multiplexes 16 differential analog input channels into one analog input of the DAS board. The high grade instrumentation provides software programmable gains of 0.5, 1, 5, 10, 50, 100, 500 and 1000.

Thermocouple measurements are handled easily with 889D. The board includes cold junction sensing and compensation circuitry that provides a scaling of 24.4 mV/°C. Biasing restores are includes for open thermocouples detentions of voltage measurements or 112 channels of thermocouple measurement.

1.1 Features

- Connects directly to A-82X, PCI-1800 series DAS board or 818 families with D-sub 37 connectors.
- Cold-junction compensation for thermocouples, thermocouple open detection.
- Software-programmable instrumentation amplifier
- Gain of 0.5, 1, 5, 10, 50, 100, 500, 1000
- Daisy chain to ten DB-889D

1.2 Applications

- Energy management
- Signal conditioning
- Analog Multiplexer

1.3 Specification

- Accepts thermocouple type : J, K, T, E, S, R, B
- Cold-junction Compensation : +24.4 mV/°C , 0 V at 0 °C
- Overvoltage protection : ±30 V Continuous
- Common mode voltage : ±10 V max.
- Analog output Voltage to A/D card :±10 V

Gain	Common Mode Rejection	Non linearity %of FSR	Settling Time
0.5	99dB	±0.0004	23 μs
1	99dB	±0.0004	23 μs
5	114dB	±0.0004	28 μs
10	99dB	±0.0004	28 μs
50	123dB	±0.0004	140 μs
100	123dB	±0.0004	140 μs
500	123dB	±0.0008	1300 μs
1000	123dB	±0.0008	1300 μs

- Power requirement : +5 V@120 mA
- Dimension : 114 mm X 204 mm
- Operating temperature : 0~60°C
- Storage temperature : -20~80°C
- Humidity : 5% to 90% non condensing

2. Installing

2.1 Layout

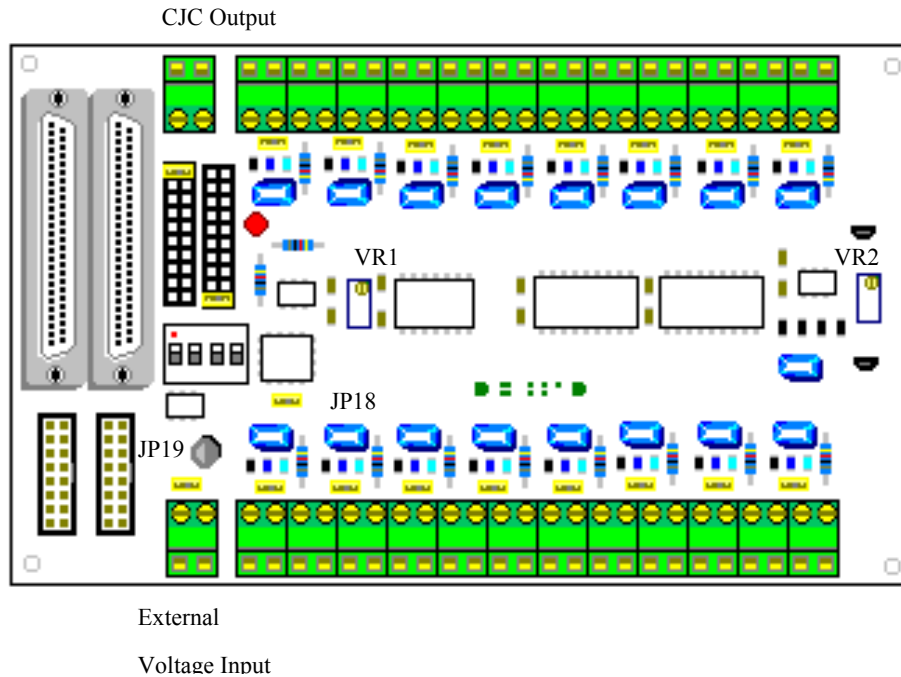

Jumper /Connector Name	Function	Note
CN1	Connect to A/D connector of A-82x series	
CN2	Cascaded to another DB-889D	
CN3	Connect to D/O connector of A-82x series	
CN4	Cascaded to another DB-889D	
CN5	External +5 V power input	Select by JP19
CN6, CN8	Analog input channel 0~ channel 15	
CN7	CJC signal output connector	
JP0~JP15	Channel 0 ~ channel 15 R/C filter enable	Short : Filter Enable Open : Filter Disable
JP16	Analog output channel selection	to A-82x series A/D card
JP17	CJC output channel selection	to A-82x series A/D card
JP18	Gain control by on board dip switch or digital output of A-82x series multi-function card	L : by dip switch R : by Digital output
JP19	Use PC's +5 V or External +5 V power	

2.2 Jumper setup

2.2.1 JP0 ~ JP15 Analog Input R/C Filter

The DB-889D provides R/C filter with each analog input channel by jumper setting.

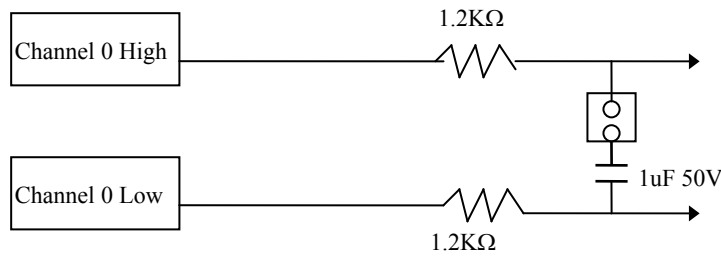

JP0~JP15

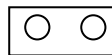

Short : with filter
Default setting



Open : Without filter

2.2.2 JP16 Analog Output Channel Jumper

The DB-889D supports 10 separate jumper to select output channel. This feature permits up to 10 DB-889D's be connected to a 10 channel analog input card. Place the jumper in the output channel according to the channel of the analog input card selected for that DB-889D board. The following table illustrates the jumper setting of using the DB-889D with the A-82X series.

	JP16 Analog output	JP17 CJC output	
X	<input type="checkbox"/> <input type="checkbox"/>	<input type="checkbox"/> <input type="checkbox"/>	X
A/D CH0	<input checked="" type="checkbox"/> <input checked="" type="checkbox"/>	<input type="checkbox"/> <input type="checkbox"/>	0
A/D CH1	<input type="checkbox"/> <input type="checkbox"/>	<input type="checkbox"/> <input type="checkbox"/>	1
A/D CH2	<input type="checkbox"/> <input type="checkbox"/>	<input type="checkbox"/> <input type="checkbox"/>	2
A/D CH3	<input type="checkbox"/> <input type="checkbox"/>	<input type="checkbox"/> <input type="checkbox"/>	3
A/D CH4	<input type="checkbox"/> <input type="checkbox"/>	<input type="checkbox"/> <input type="checkbox"/>	4
A/D CH5	<input type="checkbox"/> <input type="checkbox"/>	<input type="checkbox"/> <input type="checkbox"/>	5
A/D CH6	<input type="checkbox"/> <input type="checkbox"/>	<input type="checkbox"/> <input type="checkbox"/>	6
A/D CH7	<input type="checkbox"/> <input type="checkbox"/>	<input checked="" type="checkbox"/> <input checked="" type="checkbox"/>	7
A/D CH8	<input type="checkbox"/> <input type="checkbox"/>	<input type="checkbox"/> <input type="checkbox"/>	8
A/D CH9	<input type="checkbox"/> <input type="checkbox"/>	<input type="checkbox"/> <input type="checkbox"/>	9

If none of the output channel is used, leave the jumper in position "X". If the CJC output is required for the thermocouple applications, be aware of the analog output and CJC output share the connector that analog output and the CJC output.

Note : "X" means channels are not supported by the A-82Xseries

2.2.3 JP19 Internal / External Power selection

The DB-889D requires single +5 V power supply. The connectors CN5 are used for the external power supply connection. The A-82X series multi-function card offers +5 V power from the 37 pin connector, The DB-889D can be directly from the PC I/O bus by connecting the A-82Xseries multi-function card.

JP19



From PC's +5 V Power
Default Setting



From the CN5 input External +5 V power

2.2.4 JP18 Local / Remote Gain control

The DB-889D provides local and remote control and the selection depends on the setting of the switch SW1.

JP18



L R

Remote Gain Control
Default Setting



L R

Local Gain Control

Note :

“ L “ Local Gain control : from DB-889D on board dip switch setting

“ R “ Remote Gain control : from A-82X series A/D card digital output control

Remote Gain Control

When the JP18 is set to “R” , it means Remote Gain Control is selected and the gain is controlled by the digital signal of connector CN3 bit D4, D5, D6. The bit pattern and related gain is illustrated as:

CN3

D6	D5	D4	Gain
0	0	0	0.5
0	0	1	1
0	1	0	5
0	1	1	10
1	0	0	50
1	0	1	100
1	1	0	500
1	1	1	1000

Local Gain Control

Sw1

1	2	3	4	Gain
ON	ON	ON	OFF	0.5
ON	ON	OFF	OFF	1
ON	OFF	ON	OFF	5
ON	OFF	OFF	OFF	10
OFF	ON	ON	OFF	50
OFF	ON	OFF	OFF	100
OFF	OFF	ON	OFF	500
OFF	OFF	OFF	OFF	1000

2.3 Pin Assignment

The DB-889D provides two 37pin D-Sub connector & two 20-pin flat cable connector. The CN1, CN2 D-sub connector is analog output link to analog input connector of A-82X series multi-function card & cascaded another DB-889D. The CN3, CN4 is digital control multiplex & gain setting link to digital output connector of A-82x series multi-function card .

CN1 , CN2

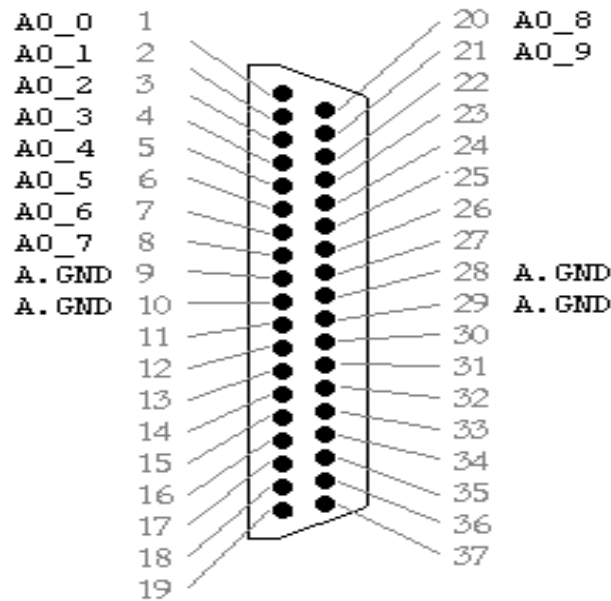

Note:

AO_n : analog output channel n

CN3 , CN4

A.GND : Analog ground

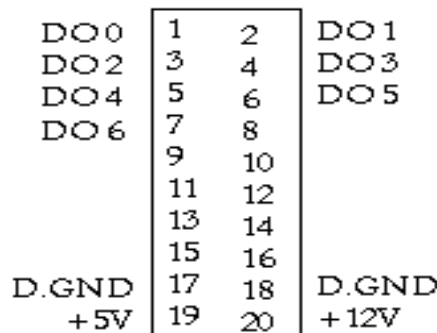

Note

DO_n : DO0~DO3 Multiplexer control bit.

DO4~DO6 Gain control bit

D.GND : Digital Ground

+5 V : PC's +5 V

+12V PC's +12 V

3 Analog input & Gain setting

3.1 Input Channel Selection

The DB-990D provides 15 channel differential analog inputs. Input channel selection is controlled by the 4 bit TTL/CMOS digital data (CN3 DO0~DO3) issued by the A-82x series multi-function card .

DO 3	DO 2	DO 1	DO 0	Analog input channel
0	0	0	0	0
0	0	0	1	1
0	0	1	0	2
0	0	1	1	3
0	1	0	0	4
0	1	0	1	5
0	1	1	0	6
0	1	1	1	7
1	0	0	0	8
1	0	0	1	9
1	0	1	0	10
1	0	1	1	11
1	1	0	0	12
1	1	0	1	13
1	1	1	0	14
1	1	1	1	15

3.2 Gain Setting

The high grade instrumentation provides software programmable gains or switch selectable gain of 0.5, 1, 5, 10, 50, 100, 500, 1000.

Software Setting : JP18 should be place on “R”

Switch Setting : JP18 should be place on “L”

Software Setting (Remote control)			Switch Setting (Local Control)			Gain	
DO 6	DO 5	DO 4	SW1-3	SW1-2	SW1-1		
0	0	0	ON	ON	ON	0.5	
0	0	1	ON	ON	OFF	1	
0	1	0	ON	OFF	ON	5	
0	1	1	ON	OFF	OFF	10	
1	0	0	OFF	ON	ON	50	
1	0	1	OFF	ON	OFF	100	
1	1	0	OFF	OFF	ON	500	
1	1	1	OFF	OFF	OFF	1000	

3.3. The Thermocouple Input

The DB-889D can accept thermocouple sensor to measure temperature. The DB-889D should be set to different gain value if use different thermocouple type.

If you are using A82XPGL series multi-function board to linked DB-889D you have got the gain as :

Gain = A82X Gain X DB-889D Gain

A821PGL Gain = 1 , 2 , 4 , 8

DB-889D Gain = 0.5 , 1 , 5 , 10 , 50 , 100 , 1000

Examples

A-82XPGL Series		DB-889D	Gain
1	X	1	1
2	X	1	2
4	X	1	4
1	X	5	5
1	X	10	10
1	X	100	100
2	X	100	200
4	X	100	400
1	X	500	500
1	X	1000	1000
:	X	:	:
:	X	:	:

Thermocouple type & suitable gain

TYPE E	TYPE J	TYPE K	TYPE R	TYPE S	TYPE T
-270°C to 1000°C	-210°C to 760	-270°C to 1370°C	0°C to 1760°C	0°C to 1760°C	-270°C to 400°C
-9.835 mV to 76.358 mV	-8.096 mV to 42.922 mV	-6.458 mV to 54.807 mV	0 mV to 21.006 mV	0 mV to 18.612 mV	-6.258 mV to 20.869 mV
Gain=50	Gain=100	Gain=50	Gain=200	Gain=200	Gain=200

3.3.1 Voltage - TO - Temperature Conversion

The temperature-versus-voltage relationship of a thermocouple is not linear. You can reference the thermocouple reference tables to get V to T values. Or use temperature conversion equation to get V to T values.

Temperature Conversion Equation:

$$T = a_0 + a_1 x + a_2 x^2 + a_3 x^3 + a_4 x^4 + \dots + a_n x^n$$

where

T = Temperature

x = Thermocouple Voltage

a = Polynomial coefficients unique to each thermocouple

n = Maximum order of the polynomial

	TYPE E	TYPE J	TYPE K	TYPE R	TYPE S	TYPE T
a0	-100°C to 1000°C	0°C to 760°C	0°C to 1370°C	0°C to 1000°C	0°C to 1750°C	-160°C to 400°C
a1	0.104967248	-0.048868252	0.226584602	0.263632917	0.927763167	0.100860910
a2	17189.45282	19873.14503	24152.10900	179075.491	169526.5150	25727.94369
a3	-282639.0850	-218614.5353	67233.4248	-48840341.37	-31568363.94	-767345.8295
a4	12695339.5	11569199.78	2210340.682	1.90002E+10	8990730663	78025595.81
a5	-448703084.6	-264917531.4	-860963914.9	-4.82704E+12	-1.63565E+12	-9247486589
a6	1.10866E+10	2018441314	4.835606E+10	7.62091E+14	1.88027E+14	6.97688E+11
a7	-1.76807E+11		-1.18452E+12	-7.20026E+16	-1.37241E+16	-2.66192E+13
a8	1.71842E+12		1.38690E+13	3.71496E+18	6.17501E+17	3.94078E+14
a9	-9.19278E+12		-6.33708E+13	-8.03104E+19	-1.56105E+19	
	2.06132E+13				1.69535E+20	

Note :

1. The thermocouple range of this table is this equation limited.
2. Other detail data please reference thermocouple data book.

3.4 CJC Output

The DB-889D provides Cold-Junction Compensation (CJC) for the thermocouple applications. If the CJC is required, place the JP17 in the position of the channel to be used as a CJC reference. If the CJC is not required, Place the JP17 in the position “X” .

CJC has output on connector CN7. Using a voltage meter measures CN7 which exists a voltage related to the DB-889D board temperature. The CJC voltage transfers to temperature with formula:

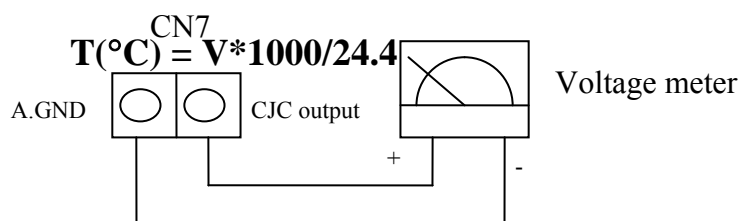

V: Voltage of CN7

T: Temperature of DB-889D

Example : (Turbo C)

Multi-Function Card : A-822PGL

If the DB-889D JP17 place on “7” .

```
/*=====Example Program =====*/
#include <stdio.h>
#include "A822.h"

main(void)
{int ad_channel , gain , trigger_mode, poll_data ;
float temp;
A822_Initialize(0,0x220, -1, -1);
/* Initials A-822PGL Ref. A-822PGH/L Software Manual */
ad_channel=7;
gain=0;
trigger_mode=1;

for(;;)
{
A822_AD_SetChGainMode(ad_channel , gain , trigger_mode );
/* Setting A822 A/D channel =7 , Gain=1 , Trigger mode = Software trigger */
poll_data=A822_AD_PollingVar();
temp=(float)((((poll_data-2048)*5/2048)*1000/24.4);
printf(" Temperature = %4.1f °C \n", temp);
}
}
```

4 Signal Connection

The DB-889D can multiplex up to 16 channel differential inputs. Input channel selection is controlled by a CN3 D4~ D6 digital output by A-82x series multi-function card.

4.1 Floating Signal Connection

The DB-889D has only differential input channels, each input channel should be two signal wires. The input should be connected as:

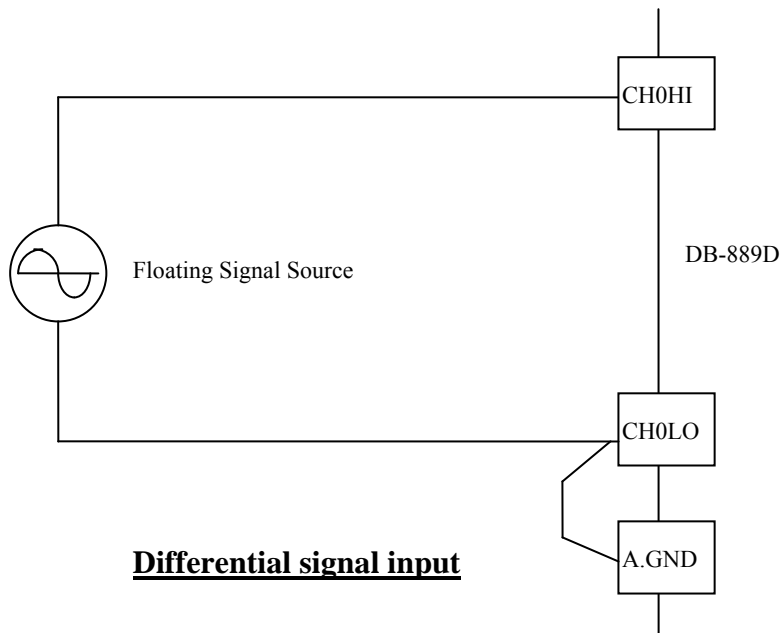

4.2 Non-Floating Signal Source

Some the signal source has one side connect to a local ground. The signal ground with DB-889D ground will not be same voltage level. The input should be show as:

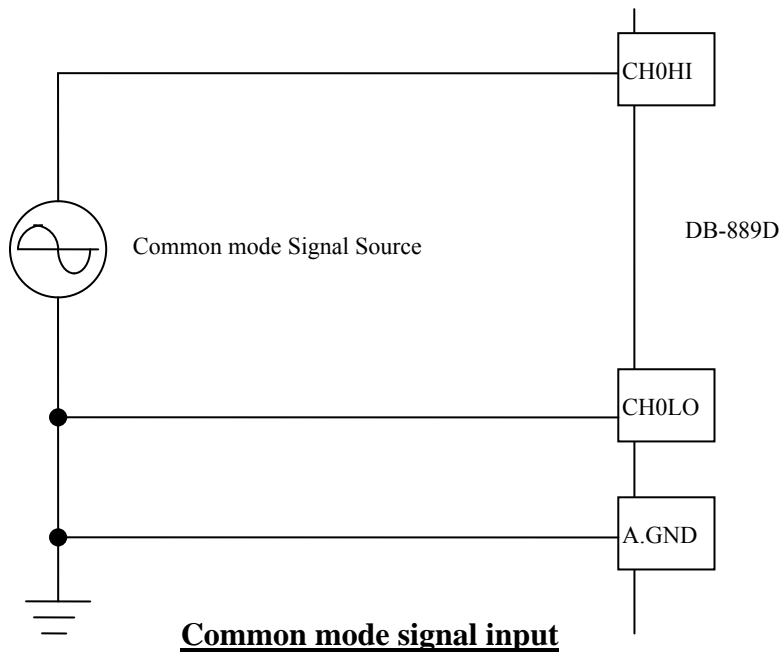

4.3 Cascading DB-889D

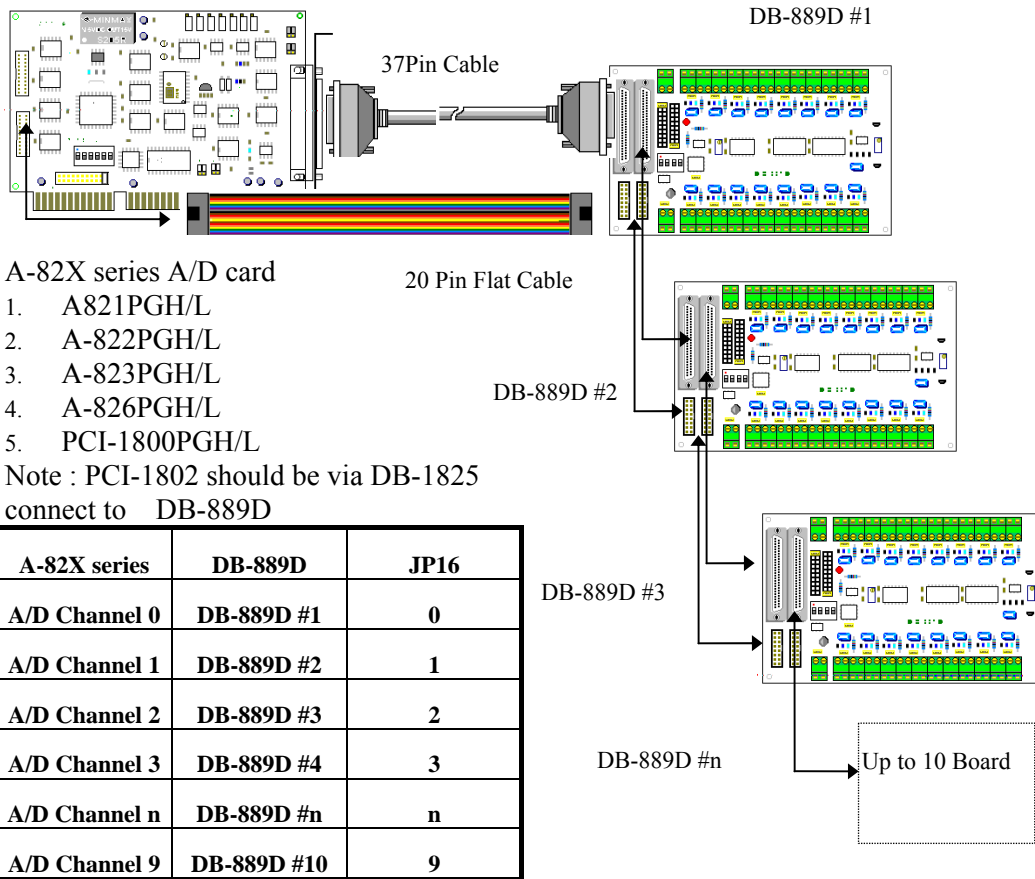

Note : Each DB-889D JP17 place on “X”

4.4 Open Thermocouple Detection

The DB-889D provides open thermocouple detection through a resistor circuitry. These resistors are normally not connected. The user can find on the back of the board has two solder gaps for each input channel. If you short the solder gaps, the open thermocouple detection is enabling.

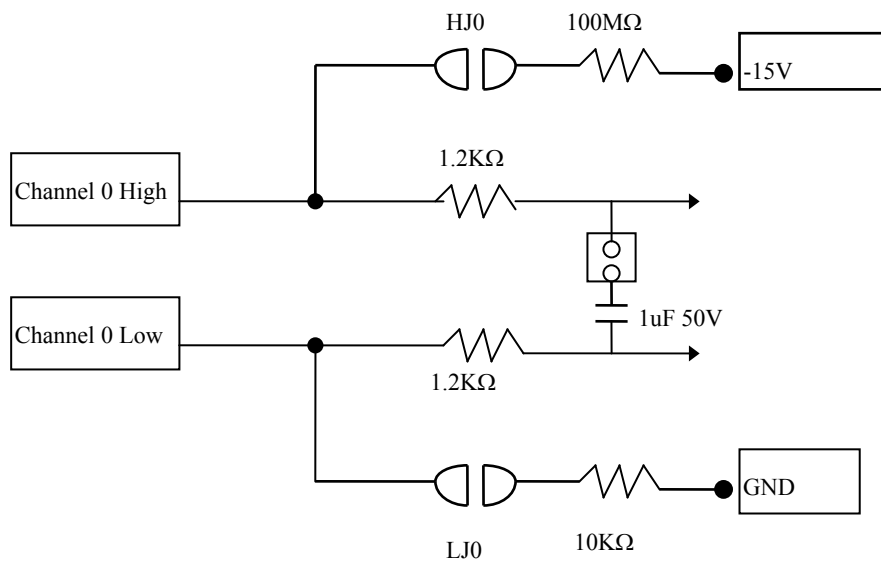

Note :

If a thermocouple opens, the bias resistor will slowly pull the input voltage to -10V then user can use a simple application program to detect the voltage change.

4.5 Block Diagram

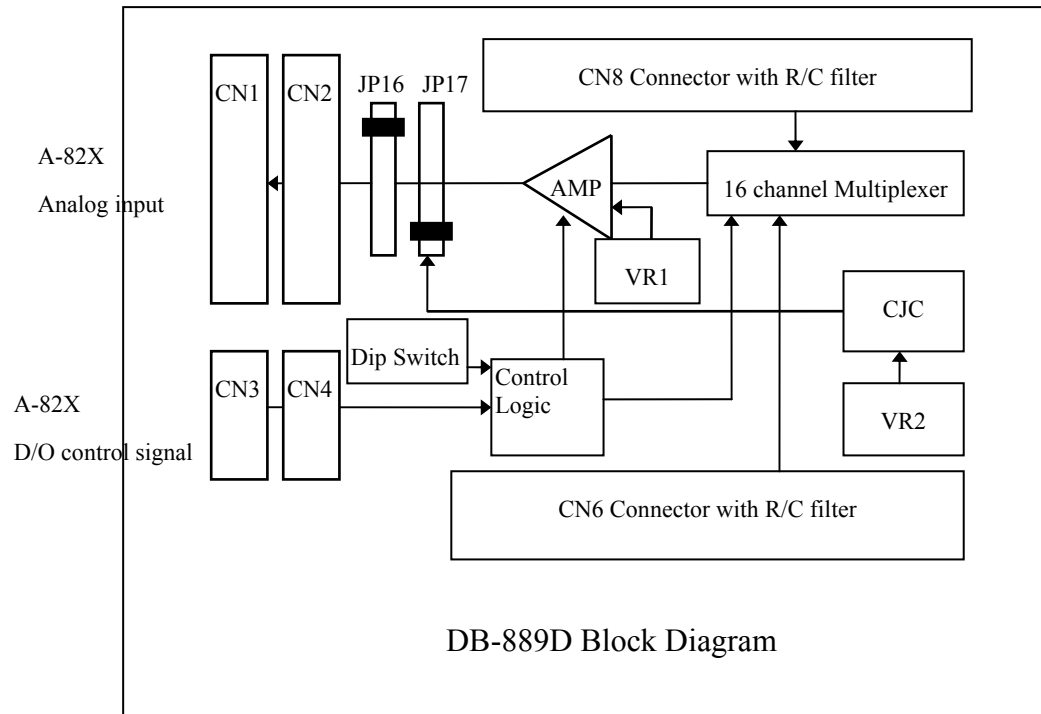

CN1: connect to A-82x series multi-function card

CN2: connect to CN1 of another DB-889D

CN3: connect to A-82x series digital output

CN4: connect to CN3 of another DB-889D

AMP: programmable gain amplifier (PGA).

VR1 : PGA off-set adjustment.

VR2 : CJC gain adjustment

5 Programming

The A-82x series multi-function card can support up to 160 channel by cascading 10 DB-889D's. And this is very easy to programming DB-889D.

5.1 Using A-822PGL

This section will use A-822PGL to link DB-889D.

The major step are listed below:

Step 1 Hardware installing.

1. Turn off power of computer.
2. Plug in A-822PGL then connect 37 pin cable & 20 pin flat cable to CN1 and CN3 of DB-889D.
3. setup DB-889D (Ref. Jumper setting section of DB-889D. the example program use default setup)
4. Connected your signal wiring.
5. Turn on your computer power.
6. Installing A-822PGL C library.
7. Now your ready to programming.

Step 2. Software programming (C Language)

1. Using A-822 library function to initial A-822PGL
2. Setup A-822PGL : Bipolar mode , Gain = 1 , Analog input channel = 0 , Trigger mode = Polling mode.
3. Send digital output of A-822PGL data to control DB-889D
D0~D3 : DB-889D channel selection , D4~D6 : DB-889D Gain setting
4. Reading A-822PGL analog input data
5. Conversion data to voltage or temperature

Note :

The A-82X series programming step same as A822PGL

5.2 Example Program

```
DEMO_01.C
/* ===== Using A-822 / connect one DB-889D
===== */

#include <stdio.h>
#include "A822.h"

main(void)
{int data1,data2;
float vol1,vol2;
A822_Initialize(0,0x220,-1,-1);
/* A-822 Base address in 0x220 ref. A-822 Software manual */

for(;;)
{
/*=====reading DB-889D Channel 0 , Gain =1 =====*/
A822_AD_SetChGainMode(0,0,1);
/* Setup A-822 A/D channel 0, Gain = 1 , Polling mode */
A822_DO(0x0010);
/* Send D/O data to DB-889D , Channel 0, Gain=1 */
delay(10); /* delay about 43u sec . Ref. Page 3 Settling time */
data1=A822_AD_PollingVar();
/* Reading A-822 A/D data */
vol1=(float)((data1-2048)*5/2048);
printf("DB-889D channel 0= %6.4f V\n",vol1);

/*=====reading DB-889D Channel 1 , Gain=10 =====*/
A822_AD_SetChGainMode(0,0,1);
/* Setup A-822 A/D channel 0, Gain = 1 , Polling mode */
A822_DO(0x0021);
/* Send D/O data to DB-889D , Channel 1, Gain=10 */
delay(10); /* delay about 43u sec , Ref. Page 3 Setting time*/
data2=A822_AD_PollingVar();
/* Reading A-822 A/D data */
vol2=(float)((data2-2048)*0.5/2048);
printf("DB-889D channel 1= %6.4f V\n",vol2);
}
}
```

}

6. Calibration

The DB-889D is calibrated to its best of operation. For environment with large vibration, recalibration is recommended. Before calibrating the DB-889D, user should take care the following issue:

- One 6 digital voltage meter.
- One temperature meter
- One A-82x series multifunction card

6.1 Calibration VR Description

There are two VRs on the DB-889D .

VR Num.	Description
VR1	Amplifier Offset adjustment
VR2	CJC Gain adjustment

6.2 Calibration Steps

1. Turn off computer power.
2. Connect A-822PGL (Or Any A-82x series multi-function card) to DB-889D.
3. Setup DB-889D to default setting
4. Short CH0HI to CH0LO to A.GND of DB889D.
5. Connect probe of voltage meter to CN7 (CJC output :+ , A.GND : -).
6. Turn on computer power
7. Waiting about 5 minute (warn up).
8. Run Calibration program of DB-889D.
9. Close the probe of temperature meter to DB-889D them reading temperature value.
10. adjust VR1 until the screen value = 0;
11. adjust VR2 until voltage meter reading value = temperature value X 2.44 mV